

Drive Higher Data Center Performance, Reliability, and Manageability with Gen 5 (16Gb) Fibre Channel Solutions and All-flash Storage

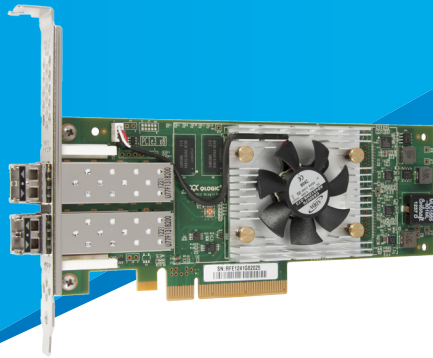

Unleash the full potential of high-density server virtualization, cloud architectures and flash storage. Upgrading from 8Gb Fibre Channel to Gen 5 (16Gb) Fibre Channel is easier than ever with new, advanced SAN management features.

KEY FINDINGS

- Fibre Channel (FC) is the proven and trusted networking technology that meets the stringent requirements for zero-data loss and flow control with mission-critical storage applications.
- A Gen 5 (16Gb) FC SAN with QLogic® Enhanced Gen 5 FC Adapters from Cavium™ and Brocade® Gen 5 FC Switches delivers transformational changes for enterprise storage networking, as well as performance and latency requirements to leverage the power of all-flash arrays (AFAs).
- QLogic StorFusion™ technology from Cavium—the fusion of features from Brocade and Cavium—automates and simplifies SAN deployment to make it easier and faster to upgrade from 8Gb FC adapters to 16Gb FC adapters by using software-defined dynamic fabric provisioning and centrally-assigned FC node assignments, which are vital in high-density server virtualization and cloud architectures with demanding, mission-critical workloads.
- Brocade Gen 5 FC with Brocade Fabric Vision™ technology accelerates data access, adapts to evolving requirements, and drives always-on business operations for hyper-scale virtualization, larger cloud infrastructures, and growing flash-based storage environments.
- Kaminario® K2 general purpose AFAs provide consistently low latency and high throughput/IOPS and handle mixed workloads and blended I/O with the ability to either scale out or scale up with adaptive block size technology. This reliable performance under load ensures that the K2 array does not become a bottleneck even during unanticipated periods of peak demand.

EXECUTIVE SUMMARY

Emerging and evolving critical workloads, higher-density virtualization, and cloud-based architectures are continuing to push the limits of SAN infrastructure and manageability. Organizations are looking for ways to escape the treadmill of reactive IT and deploy technologies that will meet their growing performance needs while providing the reliability and manageability to allow them to transform to proactive, nimble organizations. Inherent in this search is partnership with vendors who can provide the assurance and tools to facilitate this transformation.

The server, network, and storage technology advances and enterprise IT challenges that drive the need for higher performance, reliability, and manageability are:

- Application and database growth
- High-density server virtualization
- Cloud computing and application mobility
- Solid-state drives (SSDs) and AFAs

To take full advantage of the capabilities offered by these next-generation trends in technology, IT organizations must ensure the network isn't a bottleneck. Data center managers looking to gain a competitive advantage need to take a close look at their storage network infrastructure to determine whether it's capable of delivering the reliability, performance and operational simplicity required by the new technologies. If not, the bottleneck has simply moved, and you won't gain the benefits you seek.

Cavium and Brocade have worked closely together to create best-of-breed I/O solutions that help the enterprise meet these new IT challenges head-on. To validate the features and benefits of Cavium and Brocade FC solutions, Cavium test engineers performed hands-on deployment and testing of QLogic Enhanced Gen 5 FC Adapters with StorFusion technology in a Brocade Gen 5 FC fabric, connected to a Kaminario K2 all-flash storage array. Test findings demonstrated a SAN infrastructure capable

of delivering the performance, reliability, and manageability required by today's highly virtualized, cloud-enabled, transaction-intensive and flash storage use cases requiring low latency and high capacity bandwidth.

This white paper will help IT professionals to plan and execute their next-generation FC SAN to minimize bottlenecks and increase productivity, while implementing an FC ecosystem that supports required performance levels and growth plans, and responds to economic challenges.

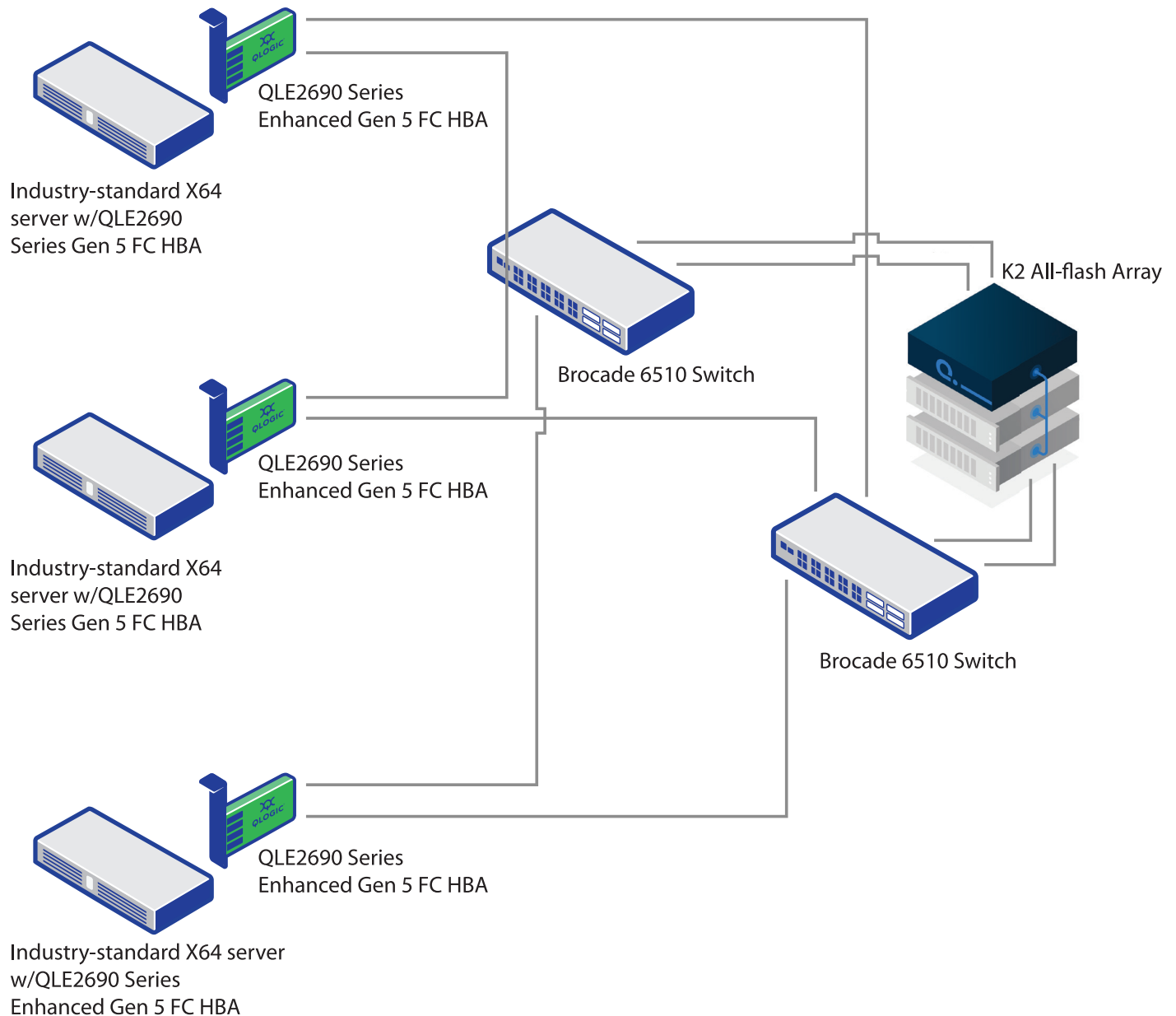

Figure 1. The test environment included industry-standard X64 servers, QLogic QLE2690 Series Enhanced Gen 5 FC HBAs from Cavium with StorFusion technology, Brocade 6510 48-port Gen 5 FC Switches with Fabric OS 7.4.0a, and a Kaminario K2 AFA.

ENTERPRISE CHALLENGES

Application and Database Growth

The storage and network must be prepared to handle increased capacity, greater throughput, and higher levels of resiliency.

The big growth in all computing environments is the increasing size and number of software applications and databases. The digitization of information and growing use of rich media and interactive Web 2.0 applications drive greater storage capacity and bandwidth requirements. From mobile access to email to cloud computing, data needs to be transported over longer distances at high speeds. In addition, demanding I/O operations like backups, database replication/failover, and OLAP business analytics and reporting are growing rapidly, yet continue to require non-stop availability. With shrinking or non-existent maintenance windows, performance issues or downtime that impact data access are simply not acceptable.

High-density Server Virtualization

The increased density of VMs drive demand for higher I/O performance, reliability and availability from the storage infrastructure.

When FC was first launched, a server was dedicated to a specific application, resulting in low utilization of server resources. The introduction of server virtualization changed that paradigm, allowing multiple applications to share a single physical server, increasing efficiency and driving up server utilization rates. Today, evolving critical workloads and Tier 1 applications are being hosted on virtual machines (VMs). In addition to increased use of server virtualization, VM densities (the number of VMs hosted on each physical server) are steadily increasing to 10, 20, or more VMs per physical server—all accessing SAN resources. The increased usage, criticality, and density of VMs drive demand for higher performance (bandwidth and I/O), as well as increased reliability and availability from the storage infrastructure. In highly virtualized environments, any congestion, poor I/O performance, or failures in the storage network impact a larger number of applications.

Cloud Computing and Application Mobility

The storage network must ensure that SLAs are met.

As IT organizations integrate more software as a service (SaaS) applications and provide private cloud infrastructures to clients, the predictability and manageability of the storage and network become even more critical. Application mobility creates an even further disaggregation between application locality and storage. This places a further burden on the storage network to ensure the IT organization is able to meet user service-level agreements (SLAs).

All-flash Storage Arrays

Networks must deliver flash-enabled storage access to servers in a scalable, consistent and latency-free manner.

The market for SSDs, non-volatile memory express (NVMe), server-based flash cards and AFAs is growing exponentially: IDC expects that the all-flash market will grow from an 800-million dollar market in 2014 to a nearly 1.6-billion dollar market by 2016. With the decreasing cost per gigabyte for flash storage, businesses will continue this adoption of flash in the compute and storage layer for high density, virtualized workloads and performance-intensive applications. Flash also provides an economically sustainable approach for data center build-outs. A single tray with 2TB of flash memory can handle 1 million IOPS, over 150 times the IOPS capacity of an HDD storage array in the same form factor¹.

The fact that flash-based platforms can provide many times the performance of standard hard drive-based platforms means the burden of delivering this performance now shifts to the networks that connect the compute and storage tiers together.

STORAGE NETWORK SOLUTIONS

Fibre Channel: Proven and Purpose-built for Data Center Storage

Enterprise IT continues to rely on FC, with 90% of Fortune 1000 data centers using FC as the defacto standard for storage networking². And with the growing adoption of SSD/flash usage and a reported 61% of AFAs attached to servers now using FC, FC SANs will continue to form the backbone of data center storage for many years to come. Its robust capabilities make it the technology of choice today, and organizations around the world have shown their confidence by investing nearly \$10 billion in FC infrastructure in 2015 and 2016³. These organizations must be able to leverage those investments for the long term as they face new enterprise challenges.

¹ [ITBrandPulse, Industry Brief: Fibre Channel Supercharged for Performance and Scalability](#), November, 2015

² [FCIA, Fibre Channel Industry Association Releases Updated Technology Roadmap: Elects 2015/16 Board of Directors](#), January 2016

³ [ITBrandPulse, Industry Brief: Fibre Channel Supercharged for Performance and Scalability](#), November, 2015

90% of Fortune 1000 data centers use FC.

61% of AFAs attached to servers use FC.

When it comes to the elevated demands of virtualization, cloud-based architectures and AFA use cases, only FC is the proven and trusted networking technology that meets the stringent requirements for zero-data loss and flow control with mission-critical storage applications.

THE POWER BEHIND A GEN 5 FC SAN

The enterprise challenges discussed in this white paper have shortened the time horizon when capabilities beyond 8Gb FC are needed. The time for high-performance Gen 5 FC with a 16Gb FC link speed and advanced SAN management capabilities is today. Backward compatibility with existing FC networks means seamless upgrades. Rapid deployment tools and technology means 8Gb FC storage networks can be upgraded to 16Gb FC effortlessly and seamlessly. Deterministic performance means data is available when required for high-performance applications, especially in a flash-based storage environment.

Flash storage arrays attached to a SAN benefit from a Gen 5 FC infrastructure because superior performance means faster storage access. QLogic QLE2690 Series Enhanced Gen 5 FC HBAs can deliver up to 2.6 million IOPS and 3000MBps per port maximum throughput. That's two times the data throughput with significantly reduced application latency and response times as an 8Gb FC solution—key components to maximize AFA technology.

Test Results: Gen 5 FC Delivers the Industry's Top Storage Networking Performance

Our tests verified that a Gen 5 FC SAN delivers transformational changes for enterprise storage networking, as well as performance and latency requirements to leverage the power of flash:

- **Increased performance with up to 2.6 million IOPS.** QLogic 16Gb FC adapters from Cavium provide two times the throughput and three times the IOPS over 8Gb FC adapters. The QLogic Enhanced Gen 5 FC solution also delivers higher performance than traditional Gen 5 FC technology, with up to 650K IOPS per port and a maximum throughput of 3000MBps per port.

- **Investment protection with backward compatibility support for two generations:** You can buy 16Gb FC today and use it in an existing 4Gb FC or 8Gb FC SAN. This means a 4Gb FC SAN infrastructure can be scaled to two times the speed without a rip and replace. It also enables a data center to leverage its long-standing SAN knowledgebase, use existing SAN tools and training, and take advantage of new technology in a nondisruptive manner.
- **End-to-end fabric integration:** Gen 5 FC delivers so much more than speed. It also delivers simplified and smarter SAN management through QLogic StorFusion, the fusion of technologies for Brocade Fabric Vision and QLogic Enhanced Gen 5 adapters that simplify deployment, streamline management and guarantee quality of service (QoS).

THE REQUIREMENTS FOR AND BENEFITS OF SIMPLIFIED FC SAN MANAGEMENT AND DEPLOYMENT

Storage fabrics have the most stringent performance requirements of any network technology. They require low latency and guaranteed delivery while supporting growing workloads and accommodating bursts in application data flows without disrupting applications. StorFusion addresses this need with a suite of powerful features designed in collaboration by Brocade and Cavium to enhance troubleshooting capabilities, quicken SAN deployment, and improve QoS. Leveraging Brocade Fabric Vision technology, the advanced SAN management features enable diagnostics, rapid provisioning, and guaranteed performance SLAs throughout the fabric.

Test Results: Smarter SAN Management Delivered by StorFusion

Our internal tests validated that StorFusion automates and simplifies SAN deployment and orchestration by using software-defined dynamic fabric provisioning and centrally-assigned FC node assignments, which are vital in high-density server virtualization and cloud architectures with demanding, mission-critical workloads. This means it's never been easier to upgrade from 8Gb FC to 16Gb FC. Its comprehensive GUI and scriptable CLI with Brocade integration improve time efficiencies by 30% as new servers are added⁴. StorFusion makes a 16Gb FC enterprise-wide storage network easier to upgrade, deploy, use, and troubleshoot than any other protocol available.

⁴ [ESG Lab Validation Report](#), March 2016

The StorFusion features that were tested and validated for this white paper are outlined in Table 1, and include a brief description of the capabilities we confirmed for each feature and the corresponding benefit to the enterprise IT operation.

Table 1. StorFusion Features and Benefits

StorFusion Features and Benefits for the Fibre Channel SAN			
Application	Feature	What it Does	Why It Matters
Advanced Diagnostics	ClearLink diagnostic port (D_Port)	Allows a switch port to be set to D_Port mode and uses Brocade Network Advisor to run diagnostics to validate the integrity of the connections, optics and cables. ¹	Reduce fabric deployment time and ensure reliable connections.
	Fabric device management interface (FDMI)	Provides rapid access to hardware configuration and counters.	Simplify change management.
	Fibre Channel ping (FC ping)	Allows users to ping an FC N_Port or end device to verify the connectivity between the host and the target in the FC fabric within Cavium QConvergeConsole® (QCC).	Maximize uptime.
	Fibre Channel traceroute (FC traceroute)	Obtains the path information between two fabric ports (F_ports) from the fabric configuration server within QCC.	Improve troubleshooting.
	Read diagnostic parameters (RDP)	Provides detailed port, media and optics diagnostics from any point in the fabric to easily discover and diagnose link-related errors and degrading conditions. ²	Save time and resources.
	Link cable beacon (LCB)	Enables administrators to visually identify both ends of a physical link without tracing the cable. ²	Simplify cable management and eliminate human errors.
Rapid Deployment and Orchestration	Fabric-assigned port worldwide name (FA-WWN)	Allows the adapter to acquire its address from a pre-configured Brocade fabric, without waiting for servers and HBAs to be connected to the environment.	Improve scalability and return on investment (ROI).
	Fabric-based boot LUN discovery (F-BLD)	Works in conjunction with the FA-WWN on Brocade switches to enable seamless boot from SAN.	Accelerate deployment.
Quality of Service	QoS class-specific control (QoS CS-CTL)	Enables administrators to set low, medium or high priority for virtual HBAs, and allows the prioritization to flow through the Gen 5 FC SAN, providing end-to-end QoS from the VM to the storage LUN.	Rapidly scale server virtualization without compromising SLAs.
	Forward error correction (FEC)	Supports higher end-to-end data rates by auto recovering from transmission errors. ^{2,3}	Improve the network's resiliency and performance.
	Buffer-to-buffer credit recovery (BB-CR)	Detects the loss of credits due to frame loss or corruption and recovers buffer credits automatically without disrupting any applications. ²	Enhance the network's resiliency and performance.

1. Brocade FOS 7.3.0a + with Fabric Vision™ license required.

2. Brocade FOS 7.4 + required.

3. FEC is supported only on link speeds of 16Gbps, regardless of whether the platform is FEC-capable; requires the transmitter training signal (TTS) mode to be ON; not supported when the HBA port speed changes to less than 16Gbps, or on HBA ports operating in loop mode or in direct-attach configurations.

FLASH PROVIDES PERFORMANCE AND VALUE FOR MISSION-CRITICAL USE CASES

In addition to the deployment, diagnostics and management efficiencies provided by StorFusion and the QLogic Enhanced Gen 5 FC Adapters from Cavium, AFA storage can also bring game-changing economics and functionality to an FC SAN over hard disk drive (HDD)-based or all-flash storage solutions. The Kaminario K2 AFA used in this test configuration combines highly flexible software-defined architecture within a tightly integrated hardware platform for maximum cost-efficiency. It includes enterprise-class resiliency with features such as a flash-optimized

propriety RAID protection, native snapshot-based replication, and HealthShield™ for continuous remote monitoring.

Test Results: IOPS/Throughput and Read/Write Performance Delivered by K2 AFA Storage

The K2 array is comprised of K-Blocks—building blocks that include Active-Active controllers, one or more drive shelves and connectivity for scaling out. The K2 platform scales out to two, three and four K-Block configurations. Even when scaling out, the cluster remains fully N-ways Active-Active.

The Kaminario K2 configuration used during the tests for this white paper consisted of a 1-K block configuration with one drive shelf, per the specifications in Table 2.

Table 2. Kaminario K2 Configurations*

	1 K-BLOCK	2 K-BLOCKS	4 K-BLOCKS
IOPS	Up to 250K	Up to 500K	Up to 1M
Bandwidth	Up to 3.2GBps	Up to 6.4GBps	Up to 12.8GBps

* Extracted from Kaminario K2 official specifications (<http://kaminario.com/product/specifications/>)

Our test results verified that the K2 flash storage array supports scale-out features for linear performance and capacity growth and scale-up features enabling scaling capacity with better density, which could result

in reducing the cost per GB. This makes it an ideal primary storage tier for a variety of customer scenarios supporting key IT initiatives such as server virtualization and high-performing databases.

Tests run by Cavium test engineers verified that the K2 AFA delivered the following results:

- Maximum IOPS driven from a 1 K-Block K2 array (using 4KB IO): 259,028 IOPS
- Maximum throughput driven from a 1 K-Block K2 array (using 64KB IO): 3.1GBps
- Mixed concurrent read/write workloads driven from a single K-Block K2 array (using 4KB read: 64%; 8KB write: 18%; 32KB read: 8%; 64KB write: 2%; 128KB read: 8%): 122,744 IOPS (see Figure 2.)

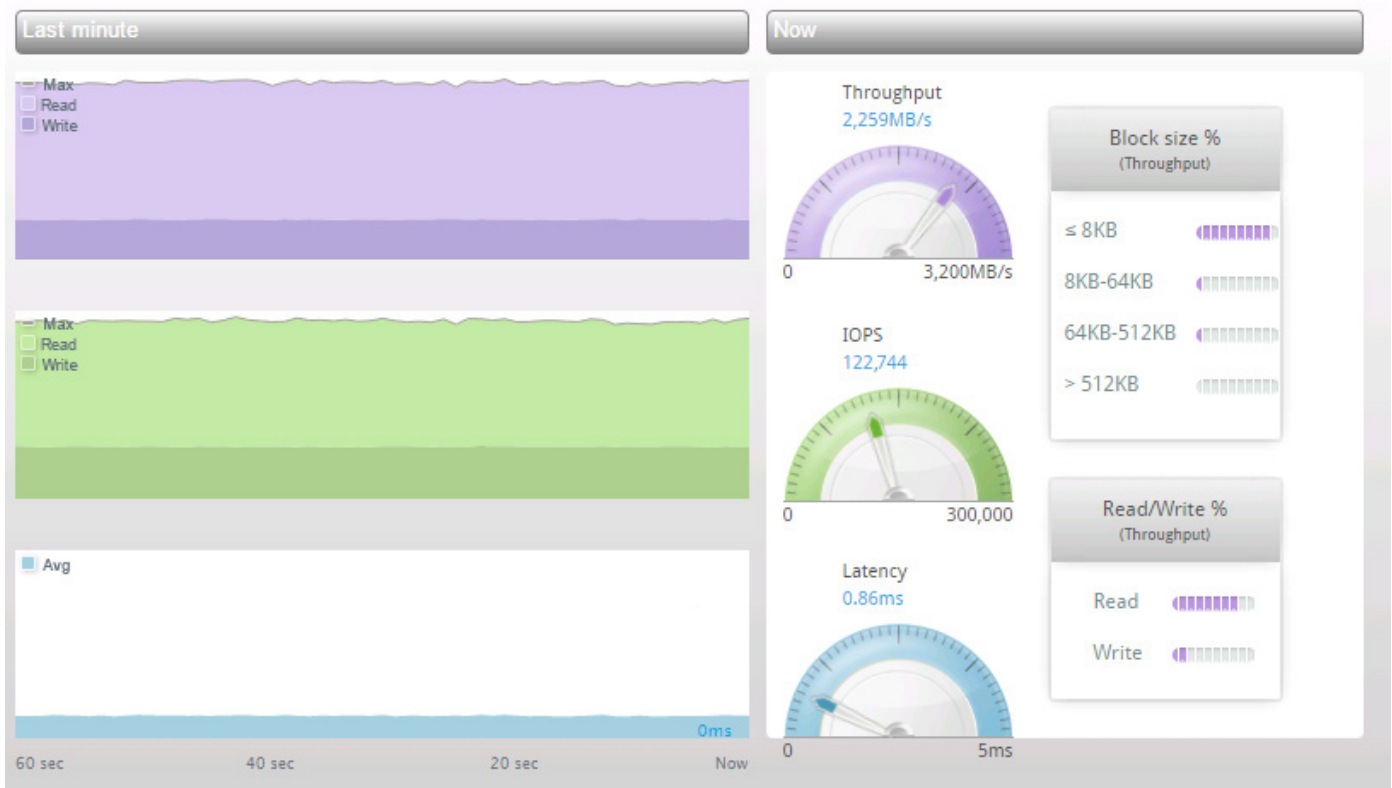

Figure 2: Predictable low latency under millisecond in mixed concurrent read/write workloads: 122,744 IOPS

An Adaptive Block Size Architecture

Workloads generated by real applications vary in their block size. Kaminario adapts to the application's block size, which generates the best performance for the application's real workload without compromising IOPS or bandwidth. The patented adaptive block size algorithm from Kaminario allows the K2 to support the real performance requirements of a multitude of application types, all running concurrently, which is the core essence of a primary storage array.

Demanding Mixed Workloads

The results of our internal tests validated that the K2 is an excellent primary storage tier for consolidating virtual servers with its ability to efficiently scale up and out to handle mixed workloads and blended I/O, while maintaining consistent throughput and low latencies. Along with its native technologies like writeable snapshots and inline compression, the K2 AFA in a Gen 5 FC SAN infrastructure enables the performance advantages of flash storage without any compromises due to demanding workloads.

CONCLUSION

Fibre Channel still reigns supreme when it comes to enterprise-wide storage deployments in which performance, reliability, and manageability dictate architectural decisions. Cavium and Brocade have innovated to make each new generation of FC a purpose-built protocol for connecting servers to shared storage, ensuring today's SAN is smarter than ever before. The performance, reliability, and manageability benefits of Gen 5 FC with StorFusion capabilities will extend the life of FC technology even more, allow companies to protect and extend their FC investments and leverage the existing SAN knowledgebase and expertise, while enabling new all-flash opportunities that are more cost-effective than hybrid or legacy storage.

QLogic Enhanced Gen 5 FC Adapters with StorFusion features and end-to-end Brocade FC fabric integration, connected to a Kaminario K2 AFA, is a strong choice for any enterprise IT group supporting virtualized servers, cloud architectures and business-critical database workloads.

RESOURCES

Learn more about building a robust storage area network to meet the needs of next-generation applications and architectures:

- [Cavium, Inc.](#)
- [Brocade Communications](#)
 - [Brocade Fibre Channel Storage Networking Solutions](#)
 - [Brocade 6510 Switch](#)
- [Kaminario](#)
 - [K2 All-flash SAN Storage](#)



Follow us:      

Corporate Headquarters Cavium, Inc. 2315 N. First Street San Jose, CA 95131 408-943-7100

International Offices UK | Ireland | Germany | France | India | Japan | China | Hong Kong | Singapore | Taiwan | Israel

Copyright © 2016 - 2017 Cavium, Inc. All rights reserved worldwide. QLogic LLC (formerly QLogic Corporation) is a wholly owned subsidiary of Cavium, Inc. Cavium, QLogic, QCovergeConsole, and StorFusion are registered trademarks or trademarks of Cavium Inc., registered in the United States and other countries. All other brand and product names are registered trademarks or trademarks of their respective owners.

This document is provided for informational purposes only and may contain errors. Cavium reserves the right, without notice, to make changes to this document or in product design or specifications. Cavium disclaims any warranty of any kind, expressed or implied, and does not guarantee that any results or performance described in the document will be achieved by you. All statements regarding Cavium's future direction and intent are subject to change or withdrawal without notice and represent goals and objectives only.