

Marvell® OCTEON Fusion-M CNF75xx

Overview

The OCTEON Fusion-M CNF75xx macro cell-on-a-chip is a full L1-L7 baseband implementation supporting up to 3600 users at 24T24R and up to 12 sectors. Multiple OCTEON Fusion-M CNF75xx chips can be cascaded for even denser deployments or higher order MIMO. The chip contains up to 16 highly optimized custom 64-bit CPU cores and multiple VLIW DSP engines along

with a host of hardware accelerators for the wireless modem pipeline, network processing and traffic shaping. This CNF75xx family is designed to allow system OEMs and operators to build next generation networks in 3G/4G macro cell and Cloud RAN deployments.

Block Diagram

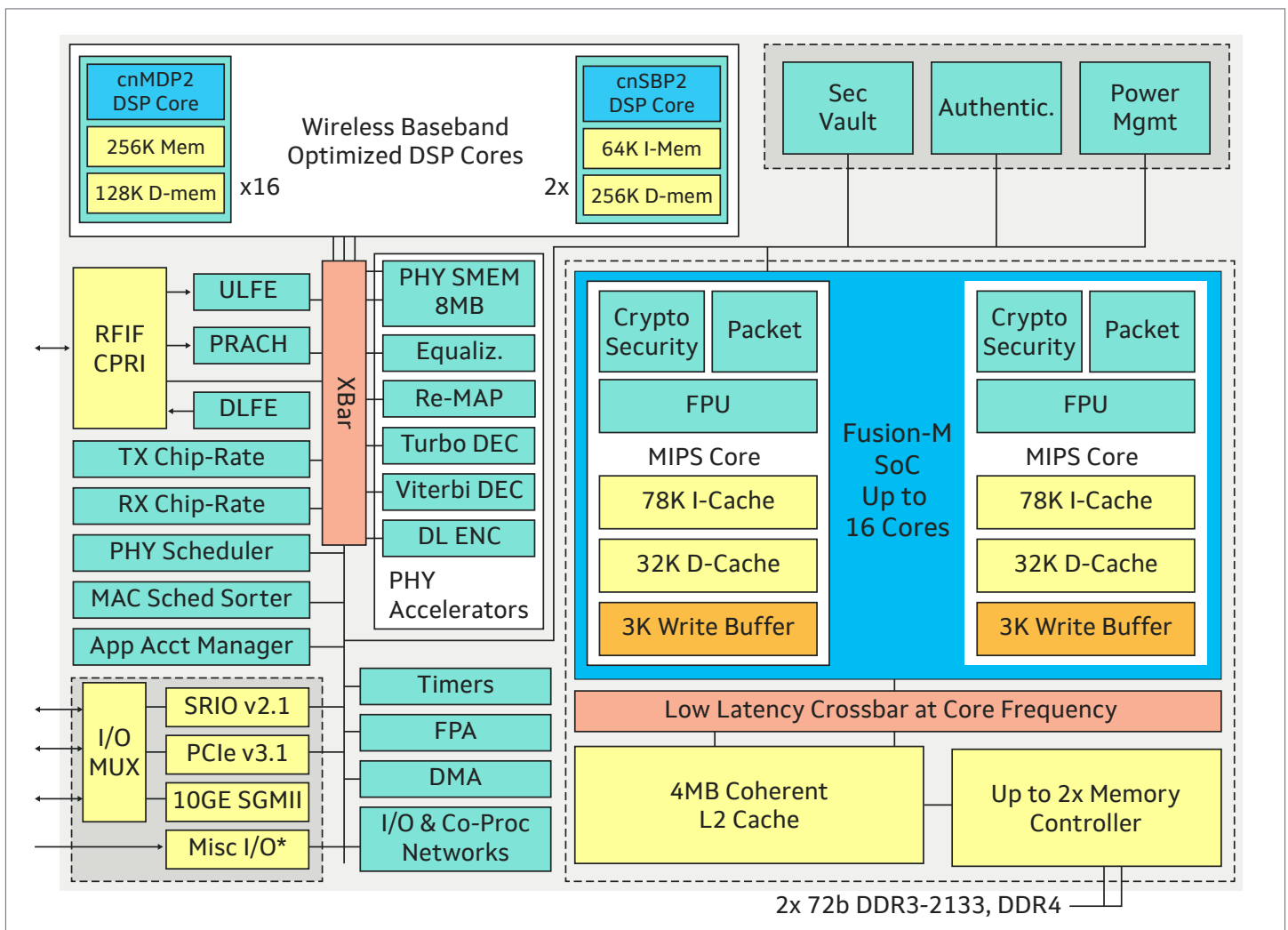

CNF75xx Block Diagram

Features and Benefits

- Part of a family of processors from enterprise small cells to macro cells and intelligent remote radio heads that allows software reuse across all products.
- Highly integrated solution – reduces system BOM cost and power consumption
- Highly flexible architecture – same silicon supports from single sector 24T24R to 6 sector 2T2R configurations

Specifications

- Up to 16 OCTEON III processor cores at clock speeds up to 1.8GHz
- CPRI v5 and JESD204B RF interfaces
- Low latency crossbars – both for CPU cores and PHY elements
- I/Os include: 4 x 10GE, 4 x SGMII, 2 x sRIO, 2 x PCIe 3.0
- Hardware cryptographic and CRC acceleration
- Hardware packet processing acceleration
- Hardware work queueing, scheduling, ordering and synchronization
- Support for DDR3 and DDR4 memory modules

Applications

- Single chip macro base stations capable of supporting up to 3000 users.
- High-capacity macro base stations using multiple CNF75xx chips for up to 18 sectors and 9000 users.
- Intelligent remote radio head (IRRH) for use with advanced C-RAN front-haul applications.

Libraries and software support:

- LTE L1 sample PHY
- LTE L2-L3 sample stack



To deliver the data infrastructure technology that connects the world, we're building solutions on the most powerful foundation: our partnerships with our customers. Trusted by the world's leading technology companies for 25 years, we move, store, process and secure the world's data with semiconductor solutions designed for our customers' current needs and future ambitions. Through a process of deep collaboration and transparency, we're ultimately changing the way tomorrow's enterprise, cloud, automotive, and carrier architectures transform—for the better.

Copyright © 2020 Marvell. All rights reserved. Marvell and the Marvell logo are trademarks of Marvell or its affiliates. Please visit www.marvell.com for a complete list of Marvell trademarks. Other names and brands may be claimed as the property of others.

Marvell_CNF75xx_PB Revised: 10/20