

Marvell® Ara T 1.6T Transmit-retimed PAM4 DSP

1.6T (8x200 Gbps) PAM4 DSP for optical transceiver applications

Overview

The Marvell® Ara T transmit-retimed PAM4 DSP is a next generation solution for AI and cloud pluggable optical transceivers. The Ara T DSP features eight 200 Gbps/channel PAM4 host electrical interfaces, and eight 200 Gbps/lane PAM4 optical interfaces with integrated differential laser-modulator drivers.

The Ara T device is manufactured using advanced 3nm process technology that delivers improved power efficiency while doubling the total bandwidth of the module to 1.6 Tbps utilizing the established OSFP/QSFP-DD form factor.

The direct drive capabilities of the DSP further simplify manufacturing complexity while saving additional power, making the Ara T DSP ideal for 1.6T DR8 modules. The DSP also integrates advanced diagnostic features associated with host side interface including performance monitoring of SNR, histogram, on the Line side interface. The device also adds PRBS generators.

The Ara T DSP supports multiple industry standard protocols up to 200 Gbps per channel.

Block Diagram

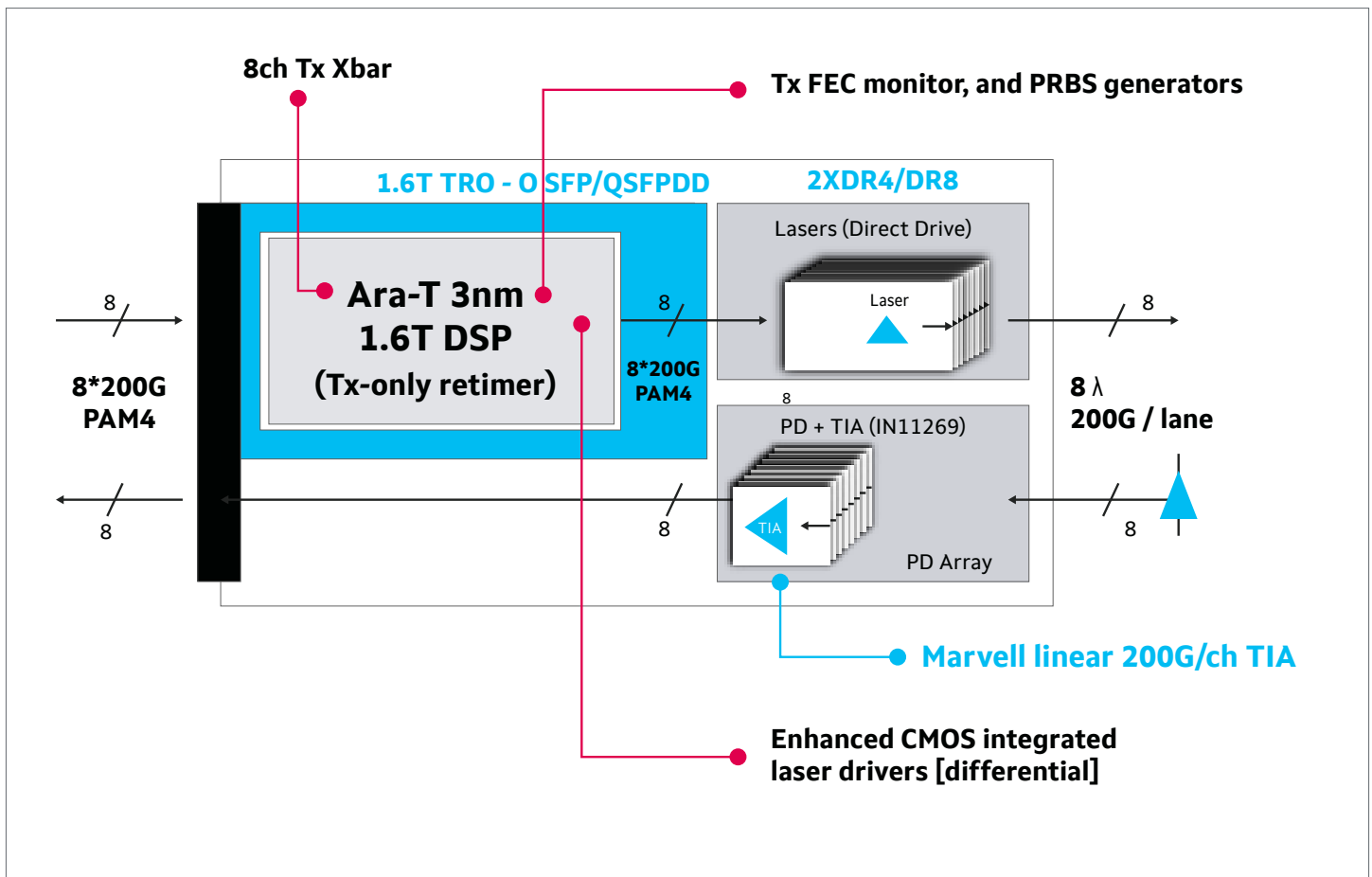

Key Features

1.6TbE, 2x800GbE, 4x400GbE, 8x200GbE operating modes	<ul style="list-style-type: none">• Support multiple operating modes with 1.6Tbps aggregate bandwidth per transceiver• Enables support of 50G PAM4 and 100G PAM4 electrical I/O for legacy infrastructure
Integrated differential laser- modulator drivers	<ul style="list-style-type: none">• Reduces transceiver design complexity while delivering cost and power savings
CEI-224G-MR, IEEE802.3dj compliant host electrical interface	<ul style="list-style-type: none">• Enables 102.4T switch architectures using traditional PCB trace-out to “face-plate” pluggable transceiver ports
IEEE 802.3dj compliant optical line-side specifications	<ul style="list-style-type: none">• Optimizes transceiver performance based on interconnect impairments.
8x8 any-to-any cross bar from host to line side	<ul style="list-style-type: none">• Enables board routing flexibility for the high speed I/Os
Ethernet packet and PRBS generation capabilities, and deep eye monitoring capability on all high-speed interfaces	<ul style="list-style-type: none">• Comprehensive test and debug capabilities for transceivers and system hardware

Target Applications

Pluggable optical transceiver modules and active optical cables (AOC) in compliant MSA form-factors: OSFP and QSFP-DD.

- 1.6T/800G optical interconnect for AI compute nodes
- 1.6T/800G data center networking fabric optical modules
- 1.6T/800G transmit-retimed optics (TRO/LRO) optical modules



To deliver the data infrastructure technology that connects the world, we're building solutions on the most powerful foundation: our partnerships with our customers. Trusted by the world's leading technology companies over 25 years, we move, store, process and secure the world's data with semiconductor solutions designed for our customers' current needs and future ambitions. Through a process of deep collaboration and transparency, we're ultimately changing the way tomorrow's enterprise, cloud, automotive, and carrier architectures transform—for the better.

Copyright © 2026 Marvell. All rights reserved. Marvell and the Marvell logo are trademarks of Marvell or its affiliates. Please visit www.marvell.com for a complete list of Marvell trademarks. Other names and brands may be claimed as the property of others.